

BESPOKE BOXES AND PACK DESIGN

Let us help you with your bespoke packaging, whether you are looking for a traditional case, ecommerce pack or a high impact design for retail.

Our pack designs add value to your products, improving their protection, enhancing your brand, and minimising waste. We offer a huge range of packaging styles, materials and printing and we are always happy to advise.

IN-HOUSE DESIGN AND MANUFACTURER

We began manufacturing in the 1970s and continue to be one of the leading independent, bespoke corrugated packaging companies.

Our portfolio includes large heavy-duty boxes and wraps to small colourful, die-cut boxes and fitments for delicate items.



Whether you are a manufacturer, wholesaler or ecommerce business we are ready to help you.



Why not have the FSC logo incorporated into your design to show your commitment to sustainability?



We are certified by the Forest Stewardship Council (FSC®), a world leader in sustainable forest management. The FSC® label means that materials used come from responsibly managed forests.

CREATIVE DESIGN

We will help you design the packaging to suit and fit your product exactly, thereby reducing damage, minimising packaging and eliminating unnecessary waste. Designs follow the industry standard (FEFCO) codes but can be adapted to suit specific requirements.

Adding your eye-catching logo and company details will also enhance your brand and create awareness, improving your customer's unboxing experience and creating the 'wow' factor.

We will produce a prototype sample to ensure your pack meets your objectives.



CUSTOMISE YOUR BOX IN 4 EASY STEPS...

1 Box style

Our designs follow and expand on the standard industry styles. Take a look at our most popular styles below, but there are many more to choose from if you can't see the style you want look [here](#).

TOP 3 POPULAR STYLES

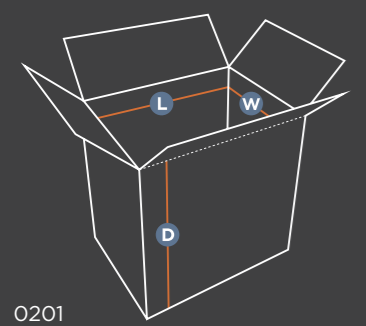

0201

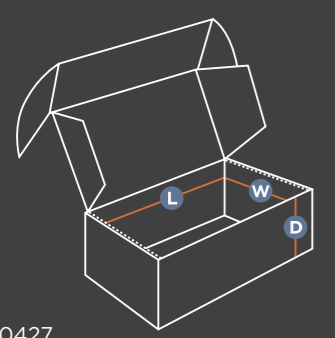

0427

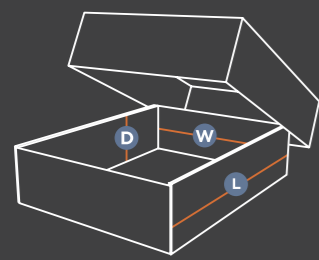

0330

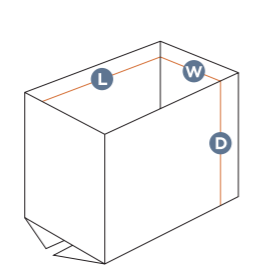

0200

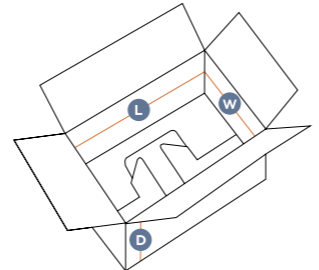

0216

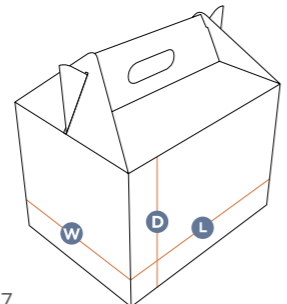

0217

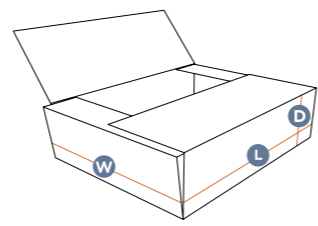

0401

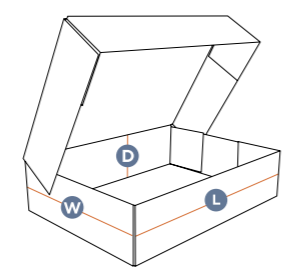

0409

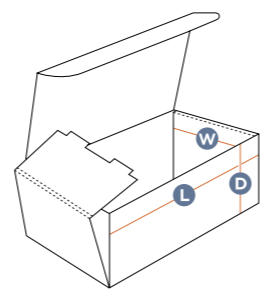

0421

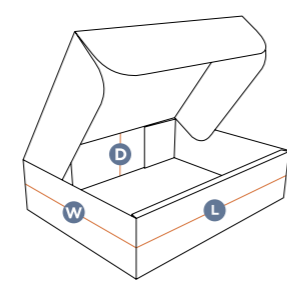

0426

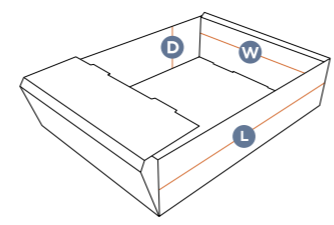

0422

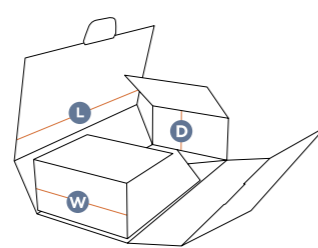

0473

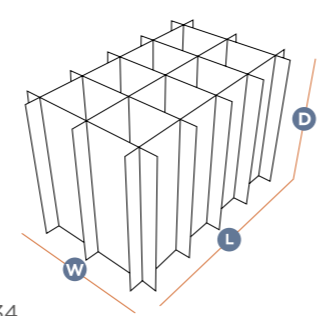

0934

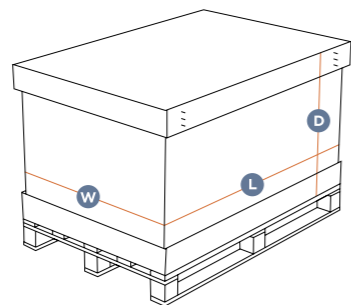

PALLET PACK

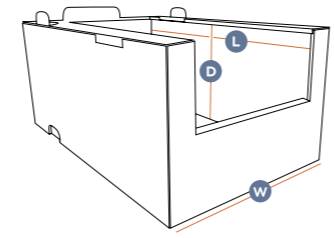

STACKING PICKING BIN

2 Box size

Determine the size of your box by measuring the length, width and depth of your product. Box dimensions are measured internally to ensure they fit your product correctly.



3 Material

The performance of your bespoke box is dependent on the paper liner and fluting which both can be varied in terms of grammage and recycled content. Consider new, lighter weight flutes which use less material without forfeiting strength and are great to print on.

The outer liner is often 'Kraft', a strong, less porous, moisture resistant paper, whereas the inner liner can be "Test" which contains a high percentage of recycled content.

Let us know about your product and its journey so we can help you advise you on the correct material.

FLUTE PROFILES

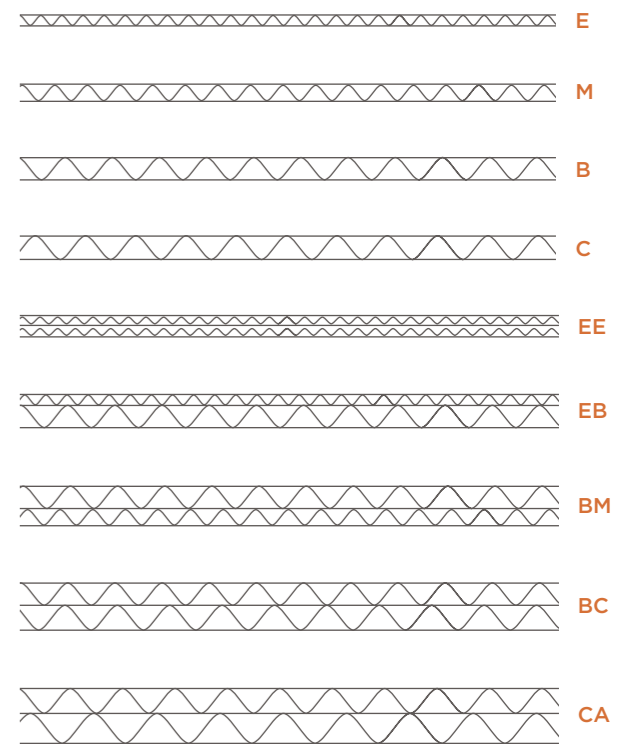

4 Plain or printed?

If you would like printed packaging, select the design and colours you require.

We will be happy to advise on alternative print finishes.



HEAVY DUTY, FOLDERS & LARGE FORMAT BOXES

Corrugated credentials are well known in the industrial sector & particularly for heavy duty boxes & export packs.

- Double wall corrugated in a variety of grades.
- Small or large quantities.
- Folders for wrapping for easier packing of long or large products.
- Inter warehouse storage.
- Pallet Boxes or boxes with pull down panels for easy-filling.
- Ensure optimum protection for your products whilst keeping packaging to a minimum.



DIE CUTS AND FITMENTS

Die cut boxes & fitments are produced using a tool (or die) to cut out the intricate designs.



E-COMMERCE PACKAGING

Enhance your brand and improve usability with our double self seal ecommerce packaging solutions, perfect for sending and returning items.



CHOICE OF PRINT FINISHES

Choosing the print process is not easy. There are so many factors to consider; brand fit, printing surface, quantity required, product life cycle, budget. We can help you choose the right print for your product.



FLEXOGRAPHIC PRINTING

This printing process is the most common for corrugated packaging and uses a flexible rubber or polymer relief plate (stereo) for each ink colour. It is a cost effective but good standard of print and ideal for corrugated printing and continuous designs.



LITHOGRAPHIC PRINTING

Suitable for high-end, magazine quality reproduction of images. This is a high quality and consistent printing method whereby an image, from a metal plate is transferred onto a rubber blanket and the image transferred onto the material by applying pressure.



DIGITAL PRINTING

In digital printing, an image is sent directly to the printer using a digital file, with CMYK colour process print. This is suitable for multicolour designs and images. The ink is applied directly onto the surface, removing the need for a printing plate.